

ROTAX®

OPERATOR'S MANUAL

125 SENIOR MAX EVO
125 JUNIOR MAX EVO
125 MINI MAX EVO
125 MICRO MAX EVO

KART ED. 04/2024
PART NO. 297732
ROTAX-KART.COM



GENERAL INFORMATION

BRP-ROTAX RECOMMENDS PRODUCTS
OF THE FOLLOWING COMPANIES:



Table of Content

Chapter	INTRO – GENERAL INFORMATION
Chapter	1 – Technical Description
Chapter	2 – Engine
Chapter	3 – Engine calibration
Chapter	4 – Engine operation
Chapter	5 – Preservation and transport

BRP-Rotax
Operators Manual

NOTES

BRP-Rotax
Operators Manual

Chapter: INTRO
GENERAL INFORMATION

Preface

Before operating the engine, read the Operators Manual carefully.

If any passages of the Manual are not clearly understood or if you have questions, please contact an authorized Distribution or Service Center for ROTAX®-kart engines.

This document and all technical data and procedures therein are property of BRP-Rotax GmbH & Co KG and based on the state of knowledge at the time of publication The Manual has been drawn up to the best of our knowledge. However, excluding any liability. We reserve all rights including technical modification and possibility of errors. Reprinting, translation or copies in whole or in part, are authorized only after written permission by BRP-Rotax GmbH & Co KG.

BRP-Rotax GmbH & Co KG reserves the right at any time to discontinue or change specifications, prices, designs, features, models or equipment without incurring obligation. Engine performance may vary depending on, among other things, general conditions, ambient temperature and altitude.

Contents

This Operators Manual contains instructions about how to operate the ROTAX®-Engine Type 125 MAX evo, 125 Junior MAX evo, 125 Mini MAX evo and 125 Micro MAX evo.

BRP-Rotax Operators Manual

Safety Messages The types of safety messages, what they look like and how they are used in this guide are explained as follows: The safety alert symbol indicates a potential injury hazard.



Figure 1.1: Safety alert symbol

⚠ WARNING
Indicates a potential hazard, if not avoided, could result in serious injury or death.

⚠ CAUTION
Indicates a hazard situation which, if not avoided, could result in minor or moderate injury.

NOTICE
Indicates an instruction which, if not followed, could severely damage vehicle components or other property.

ENVIRONMENTAL NOTE
Environmental notes give you tips on environmental protection.

NOTE

Indicates supplementary information which may be needed to fully complete or understand an instruction.

✓ Denotes a checking operation

TIP This information gives you additional advice and tips

⚠ WARNING
This vehicle may exceed the performance of other vehicles you may have ridden. Take time to familiarize yourself with your new vehicle.

Chapter: 1
TECHNICAL DESCRIPTION

TOPICS IN THIS CHAPTER

Design of the ROTAX engine types 125 MAX evo, Junior MAX evo, Mini MAX evo and Micro MAX

evo	2
General	2
Cooling circuit	2
Balance shaft	2
Ignition unit	2
Electric starter	2
Electro pneumatically exhaust timing control (125 MAX only).....	3
Intake silencer	3
Exhaust system.....	3
Fuel pump	3
Carburetor	3
Centrifugal clutch	4

DESIGN OF THE ROTAX ENGINE TYPES 125 MAX EVO, JUNIOR MAX EVO, MINI MAX EVO AND MICRO MAX EVO

GENERAL

The Rotax 125 MAX evo engine is a single cylinder two stroke engine with reed valve controlled inlet and 125 cm³ displacement. Mixture lubrication is achieved by adding oil to the gasoline in a specified mixing ratio.

COOLING CIRCUIT

The coolant is pumped from the radiator to the water pump which is driven by the clutch shaft. The water pump conveys the coolant through cylinder and the cylinder head back to the radiator.

The cooling circuit is equipped with a thermostat (opening point 45 °C / 113 °F). It assures that the engine reaches its operating temperature quickly and keeps it at a relatively constant level.

The thermostat is integrated in the cylinder head cover.

BALANCE SHAFT

The balance shaft rotates counter-wise to the crankshaft to reduce engine vibration.

IGNITION UNIT

The control of the ignition system is exercised by the ECU (Engine Control Unit). To calculate the ignition timing, an engine speed sensor is needed, which is installed on the bottom of the engine housing. There is no manual adjustment of the ignition system necessary and/or possible.

Even if the engine is stopped, the ignition system consumes current. After use, always set the combination switch to position "OFF", to avoid deep discharge of the battery.

ELECTRIC STARTER

By pressing the "START" button, the circuit between the battery and the electric starter will be closed by a relay. The electric starter drives the starter gear on the crankshaft via an intermediate gear with free wheeling, until the engine starts to run. An automatic switch re-set from "START" to "ON" is integrated.

ELECTRO PNEUMATICALLY EXHAUST TIMING CONTROL (125 MAX ONLY)

The engine type 125 MAX evo is equipped with an electro-pneumatic exhaust control. The E-RAVE (Electronic ROTAX Adjustable Variable Exhaust) system is controlled by an electro-pneumatic valve via the ECU. The vacuum required is provided by the engine crankcase.

If the engine is running at idle speed or below the opening point of the E-RAVE system (between approximately 8000-9000 rpm) the exhaust valve is closed. With the engine running, it closes or opens the electro-pneumatic valve of the exhaust depending on the speed and, therefore it provides optimum performance characteristics.

INTAKE SILENCER

The intake silencer incorporates an air filter to clean the intake air. The intake silencer has been designed for optimum reduction of air intake noise level and represents a tuned system with the engine.

The air filter consists of several layers and has been optimized in the area of air passage and filter to work more effectively. If soiled or during engine maintenance work, clean the filter with biodegradable products.

EXHAUST SYSTEM

The exhaust system is designed as resonance system with an after-muffler and represents a tuned system with engine.

FUEL PUMP

The fuel pump is actuated by the pulsating pressure changes in the crankcase and the pump transfers the fuel from the fuel tank to the carburetor.
An inline fuel filter (between fuel tank and fuel pump) keeps foreign particles from entering the fuel pump or the carburetor, respectively.

CARBURETOR

The carburetor (DELL'ORTO VHSB 34) is a slide type carburetor with float system. The standard main jet is suitable for almost all operating conditions. For extreme operating conditions, the main jet size must be adjusted to the actual conditions according to this manual.

BRP-Rotax

Operators Manual

CENTRIFUGAL CLUTCH

The engine is equipped with a centrifugal clutch operating in an oil bath. This clutch separates the engine from the gearbox at less than 2.500 rpm. Only at an engine speed of approx. 4.000 rpm. the centrifugal clutch is completely engaged.

BRP-Rotax
Operators Manual

Chapter: 2
ENGINE

TOPICS IN THIS CHAPTER

Operating fluids and battery	2
Coolant.....	2
Battery.....	2
Battery charging unit.....	4
Fuel.....	5

OPERATING FLUIDS AND BATTERY

See also table “important information (summary)” in Chapter 5.

COOLANT

Use only distilled water as engine coolant. If the kart is stored below the freezing temperature of water, make sure to drain the water from the cooling radiator and engine completely.

Step	Procedure
1	Open radiator cap and fill the system with coolant. Small radiator: approx. 0.52 liter / 0.137 gal for the complete cooling system Big radiator: approx. 0.7 liter / 0.185 gal for the complete cooling system
2	Close radiator cap.

NOTICE

Observe the storage conditions.

Storage below the freezing temperature of water could lead to a damage of the cooling system and the engine.

NOTICE

Exceeding the engine temperature could lead to serious engine failure.

The engine temperature should not exceed 85 °C / 185 °F.

BATTERY

See Fig. [Pos. 1: Charging connector, TYPICAL](#).

The power for the ignition unit and electric starter is only supplied from the battery. With a fully charged battery of 12 V and 6.5 Ah, the engine can be started approximately one hundred times and operated over a period of approximately five hours. With the battery voltage decreasing to approximately 11 V the point will be reached when the battery voltage is too low to generate a spark for ignition.

NOTICE

The lifespan of the battery will be drastically reduced by exhausting the battery completely.

Fully re-charge the battery before and after any operation of the kart.

NOTE

It is recommended to always carry a charged spare battery. The installed battery should be replaced with a fully charged battery before it is completely exhausted.

BRP-Rotax

Operators Manual

NOTE

If the spark plug is removed, to check if the battery still generates a spark, consider the following: with the spark plug removed it is easier for the electric starter to crank the engine, which reduces current absorption of the electric starter, resulting in battery voltage adequate to generate a spark. If the spark plug is fitted again, it may happen that the engine does not start.

NOTE

To charge a battery, the battery charging unit specified by ROTAX® and available as an accessory should be utilized (battery charger part no. 265148). When using the lithium battery available as spare part, the battery charger Optimate Lithium (part no. 581325) is mandatory.

NOTE

To be able to use the battery charger in your home country, please contact your nearest authorized ROTAX® distributor or one of their ROTAX® Service Centers to receive an adapter plug or adapter cable, respectively.

NOTE

This battery charger will switch over automatically to maintenance charge as soon as the target voltage is reached. Therefore overcharging with the result of ruining the battery will be impossible.

NOTICE

Use of any other battery charger can impair the battery life or may ruin the battery.

BRP-Rotax Operators Manual

BATTERY CHARGING UNIT

When charging the battery take note of the following:

Step	Procedure
1	Connect battery charger to the charging connector (pos. 1).



Figure 2.1: Pos. 1: Charging connector, TYPICAL

Step	Procedure
2	Connect the battery charging unit on 110-230V, 50 - 60Hz power supply. During the charging procedure, the charge indicating lamp will light up red.
3	At completion of the charging process, the control lamp will change to green, but the charging current will remain, thus warranting a fully charged battery.
4	The charging time amounts to approx. 12 hours.

NOTE

The battery charger may be connected to the battery for a longer period, as the battery takes just the current required to be fully charged.

NOTE

A non-extinguishing red control lamp, even after 24 hours of charging, indicates that the charging capacity of the battery is diminishing.

NOTE

A red/green blinking of the charging control lamp indicates transition from main charging to additional charging and does not signal a faulty battery charger.

BRP-Rotax

Operators Manual

Step	Procedure
5	Unplug power supply to battery charging unit.
6	Remove output wires of the battery charger from the battery.
7	The battery is ready again for use.

NOTICE

In addition to these directives, follow the advice of the battery charging unit manufacturer.

NOTE

When the battery is charged while not mounted on the kart, use the connector cable (part no. 266022). If needed, contact your authorized distributor or one of their ROTAX® Service Centers.

The charging condition of the battery can be estimated by using a commercially available measuring instrument.

FUEL

For engine operation, a mixture of unleaded gasoline of at least ROZ_{min.} 95 / 91 (RON +MON) / 2 and **fully synthetic** two-stroke oil, mixed at ratio 1: 50 (2% oil) has to be used.

NOTICE

Carry out a correct running-in procedure.

See Chapter 4 section: Running-in procedure for the engine.

⚠ WARNING

Non-compliance can result in serious injuries or death!

When mixing fuel and fuelling do not smoke or allow open fire. Gasoline is highly flammable and explosive under certain conditions.

⚠ WARNING

Non-compliance can result in serious injuries or death!

Never perform mixing and fuelling in closed rooms, handle fuel in well ventilated areas only.

BRP-Rotax

Operators Manual

⚠ WARNING

Non-compliance can result in serious injuries or death!
Fuel the kart only when engine is not running and the combination switch is at OFF position.

⚠ WARNING

Risk of fire and explosion!
Make sure that fuel will not splash onto hot engine components or equipment. Always wipe off any fuel spillage from the vehicle.

⚠ WARNING

Non-compliance can result in serious injuries or death!
Pay attention to the safety advice of the kart manufacturer.

NOTICE

Possible engine trouble!
Too much oil in the fuel mixture (more than 2%) could lead to engine trouble (e.g. coking of the exhaust valve, piston ring sticking).

NOTICE

Possible engine blow-up!
Insufficient amount of oil in the fuel mixture (less than 2%) could result in e.g. piston seizure.

NOTICE

Engine damage and damage to the intake system may occur.
Do not try any different sorts of fuel.

NOTICE

Before each fuelling, shake fuel container well to ensure adequate mixing of the gasoline with the oil.

NOTICE

Ensure that no contamination enters the fuel tank and the carburetor.

NOTICE

Unleaded fuel has a limited storage life.
Store only the quantity of fuel in a container which will be needed in the near future.

BRP-Rotax

Operators Manual

ENVIRONMENTAL NOTE

Don't spill fuel. Absorb spilled fuel with appropriate drying agent and ensure ecological disposal.

BRP-Rotax
Operators Manual

NOTES

Chapter: 3
ENGINE CALIBRATION

TOPICS IN THIS CHAPTER

ENGINE CALIBRATION	2
Run-in procedure	2
Performance graphs	2
Carburetor calibration	4
Automatic-set-up	5
Manual set-up	8
Change of the carburetor main jet	12
Selection of the transmission ratio	15
Exchange of the clutch drum with chain sprocket fitted	17
Changing or renewal of the chain sprocket on the clutch drum	19

ENGINE CALIBRATION

RUN-IN PROCEDURE

⚠ WARNING

Non-compliance may result in serious injuries or death!

Running-in has to be done with a "long" gear ratio and a rich main jet (2 sizes bigger than the recommended main jet based on altitude and temperature.

NOTICE

For the first 10 liters of fuel use a mixing ratio of 1:33 (= 3% or 0.3 liter oil per 10 liters of fuel).

NOTE

BRP-Rotax recommends to use XPS Kart - Tec oil.

Step	Procedure
1	15 min. up to 10.000 rpm. 15 min. up to 12.000 rpm. 15 min. full load.
2	Reduce the main jet size step by step (e.g. 172 - 170 - 168 ...).

NOTE

*Make sure that the coolant temperature reaches a minimum of 55 °C (130 °F).
At cold ambient temperature radiator needs to get partly covered by tape.*

PERFORMANCE GRAPHS

In this diagram, the different performance characteristics of the MAX engines are shown. The vertical Y-axis shows the power in kilowatts (kW). The horizontal X-axis shows the rotational speed in revolutions per minute (rpm).

For more information, please check the performance data sheets on www.rotax-kart.com.

BRP-Rotax Operators Manual

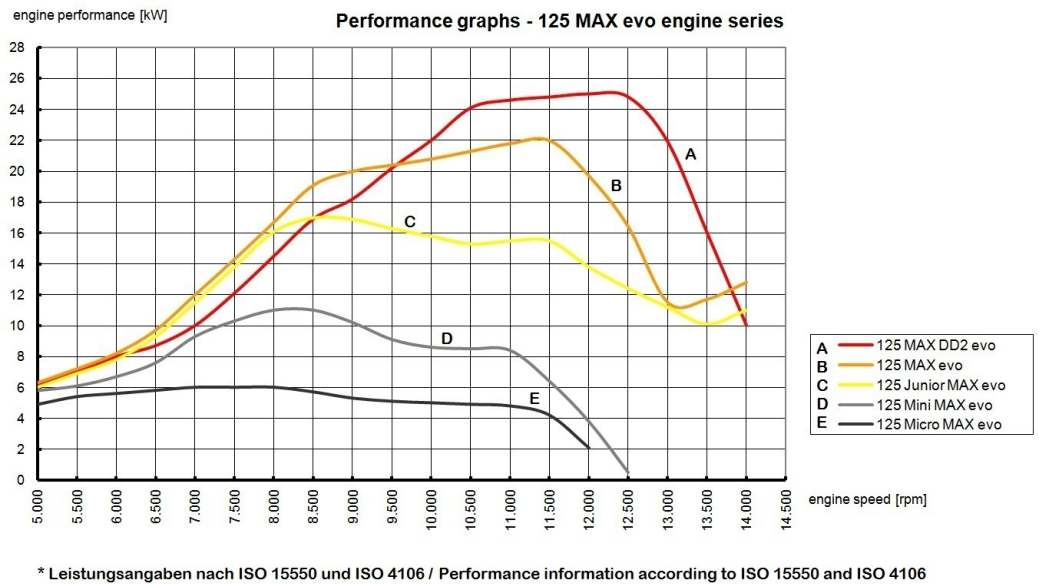

Figure 3.1: Performance graphs

BRP-Rotax

Operators Manual

CARBURETOR CALIBRATION

The standard carburetor calibration is for an ambient temperature of 25 °C / 77 °F and 400 m / 1310 ft above sea level. At operation with different temperatures and altitudes, the main jet of the carburetor has to be changed in accordance with Table 1, to optimize engine performance.

NOTE

For engine operation at an ambient temperature below 10 °C / 50 °F, make sure not to demand full power before the coolant temperature has reached 45 °C / 113 °F.

NOTE

The warranty by BRP-Rotax will no longer apply, if the carburetor calibration is carried out improperly and causes engine damage.

The following application for smartphones shows the individual setting of your ROTAX® 125 Max evo engine:

The ROTAX® Max Jetting Guide is an App for Android™ and iOS devices, designed to assist users with setting up the recommended main jet based on the ambient conditions and the type of engine. The perfect set-up can be calculated in two ways, either automatically - which requires a GPS signal and an internet connection, or manually - which requires certain knowledge about altitude and weather conditions.

BRP-Rotax Operators Manual

AUTOMATIC-SET-UP

Step	Procedure
1	Click on the blue font "Update GPS weather data" button below the weather information. After a short time the app will automatically provide all the necessary information regarding weather and geographical position.

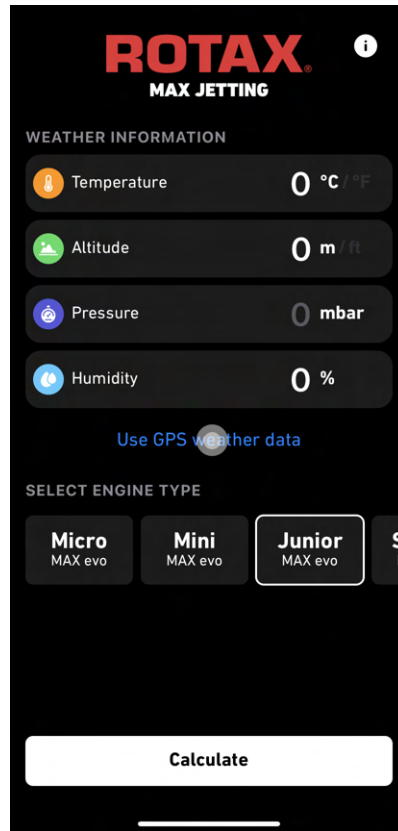

Figure 3.2

Step	Procedure
2	To select your engine type for the calculation click on one of the engine models, MICRO MAX is selected by default. You can swipe left and right to see all engine types available.

BRP-Rotax Operators Manual

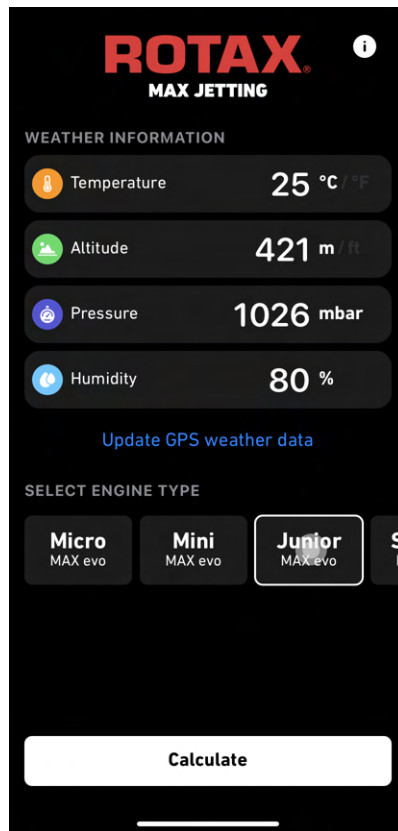

Figure 3.3

Step	Procedure
3	Having completed all fields of the weather data and having selected the engine type you can press the white "CALCULATE" button on the bottom of your screen to find out the suitable jet for your engine type and environment.

BRP-Rotax Operators Manual



Figure 3.4

Step	Procedure
4	Now the recommended main jet value will be provided. In case a second calculation needs to be made, you can start over by simply pressing the button saying “RESET” next to the calculated value.

BRP-Rotax Operators Manual

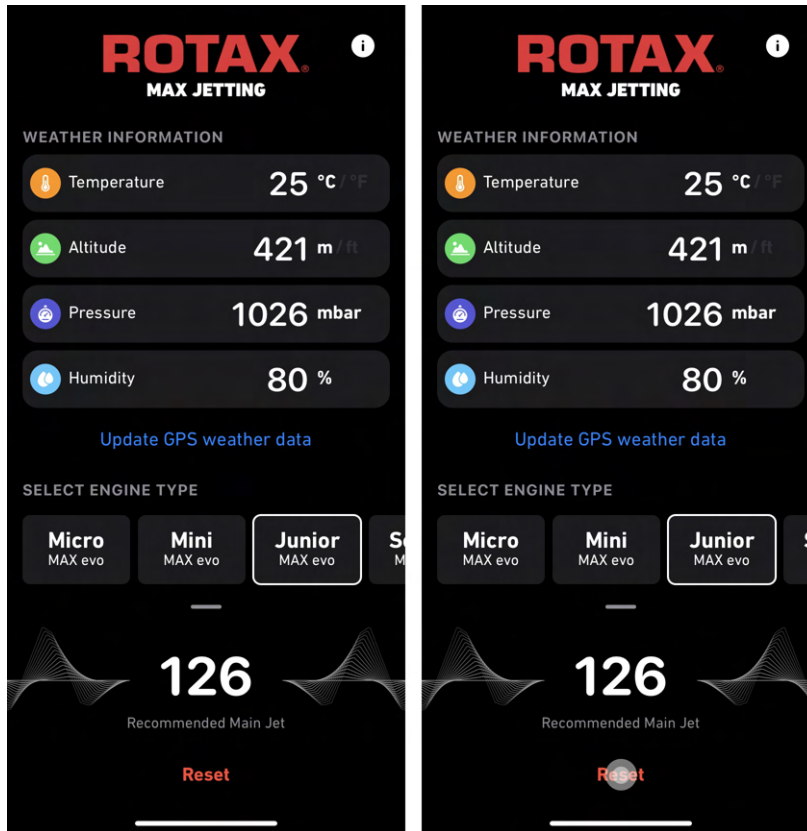

Figure 3.5

MANUAL SET-UP

Step	Procedure
1	In case no GPS signal or internet connection is available, the necessary data needs to be added manually, which of course requires knowledge about current weather conditions at the race track as well as the altitude. By clicking on the empty space next to “Temperature”, “Altitude”, “Atmos. Pressure” and “Humidity”, you are able to enter the required information. In terms of “Atmos. Pressure”, the atmospheric pressure at sea level has to be entered, usually the barometer shows the actual level.
2	As a second step, the engine type of the kart needs to be selected. Therefore, the button underneath the weather data needs to be clicked. The app will automatically show all potential Max evo engines, from which one can be selected by clicking on a certain engine type.

BRP-Rotax Operators Manual

3	After all the necessary information has been provided and selected, you only need to click the circular red button saying “CALCULATE” at the bottom of the screen.
4	Now the recommended main jet value will be provided. In case a second calculation needs to be made, you can start over by simply pressing the button saying “RESET” next to the calculated value.

Additional Information

- In case values are being entered manually, the provided numbers will turn from white to red if they are considered to be unrealistic.
- Depending on their preference, users can decide if they would like to use the metric or the imperial system. You can change between Celsius and Fahrenheit by simply clicking on the small °C or °F next to the value for temperature. The same works with feet and meter, where you can just click on the small m or ft located next to the value for altitude in order to change between the systems.

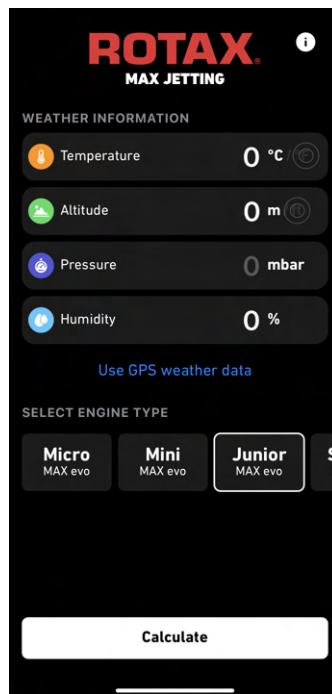

Figure 3.6

- In the top right corner, you can find a button called “INFO”. By clicking this button, additional information about the app as well as setting up the carburetor like float height, position of the jet needle or the air adjustment screw can be found. By clicking the small red X underneath the info button, you can return to the home screen.

BRP-Rotax Operators Manual

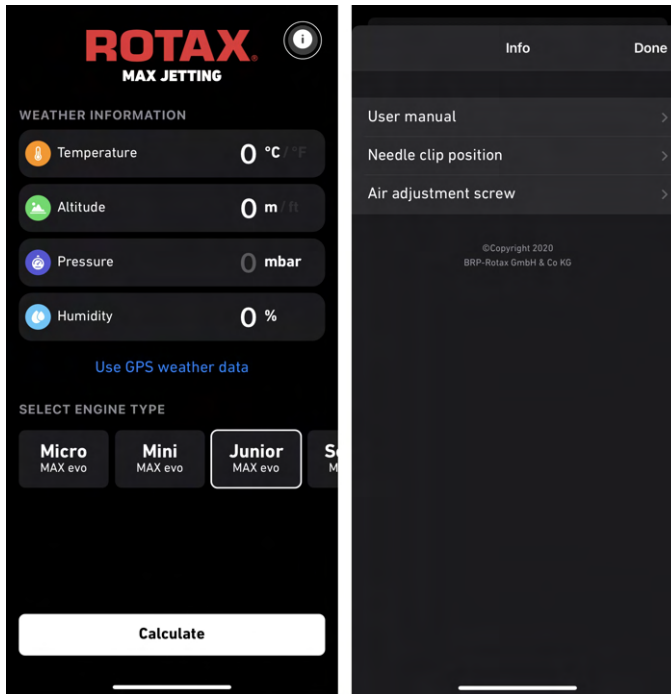

Figure 3.7

BRP-Rotax Operators Manual

App Download

Please scan the following QR-code for your mobile device:

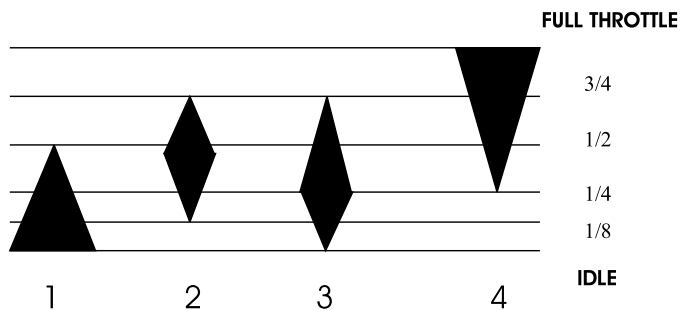

Figure 3.8: QR- code, Android device



Figure 3.9: QR- code, iOS device

For better understanding and as help for carburetor adjustment, the following figure describes the effect of the various adjustments, depending on the throttle position.



- 1 - AIR SCREW AND PILOT JET
- 2 - TYPE AND POSITION OF JET NEEDLE
- 3 - TYPE OF NEEDLE JET
- 4 - MAINJET

Figure 3.10: Various adjustments

CHANGE OF THE CARBURETOR MAIN JET

To change the carburetor main jet, proceed as follows:

Tools required:

- Open-end wrench 19 mm
- Flathead screwdriver

NOTE

The carburetor must not be removed from the engine in order to change the jetting.

⚠ WARNING

Non-compliance can result in serious injuries or death!

Handle fuel in well-ventilated areas only.

⚠ WARNING

Non-compliance can result in serious injuries or death!

When handling with fuel, do not smoke or allow open flames. Gasoline and gasoline vapor are highly flammable and explosive under certain conditions.

⚠ WARNING

Risk of fire and explosion!

Make sure that fuel will not splash onto hot engine components or equipment. Always wipe off any fuel spillage from the vehicle.

ENVIRONMENTAL NOTE

Don't spill fuel. Absorb spilled fuel with appropriate drying agent and ensure ecological disposal.

Step	Procedure
1	Drain the fuel in the float chamber into a suitable clean tray by removing the plug screw (pos. 27) and gasket ring (pos. 26). NOTE <i>The fuel drained from the float chamber may be poured back into the fuel tank.</i>
2	Remove the main jet (pos. 15) and the main jet cup (pos. 14). NOTE <i>The size of the jet is imprinted on the face of the main jet.</i>

BRP-Rotax Operators Manual

Step	Procedure
3	Select the appropriate size of main jet, refer to ROTAX® Max Jetting Guide.
4	Install the main jet cup (pos. 14) in position and fit the corresponding main jet (see ROTAX® Max Jetting Guide).
5	Fit and hand-tighten the plug screw (pos. 27) and gasket ring (pos. 26).

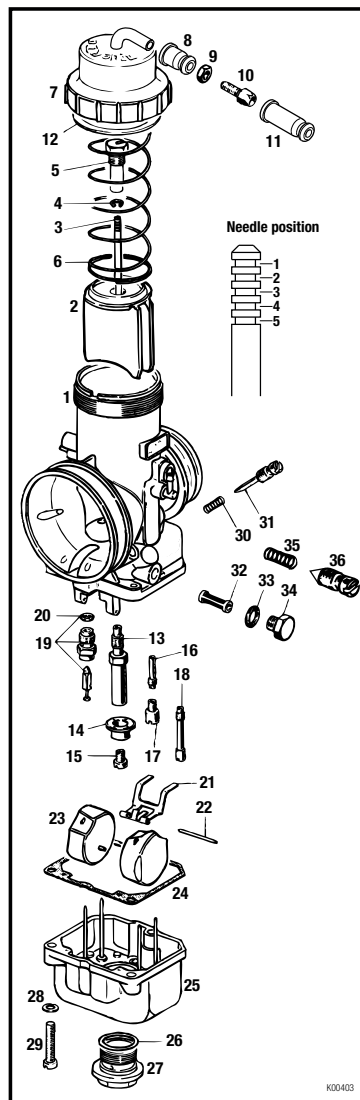

Figure 3.11: Components of carburetor

BRP-Rotax

Operators Manual

NOTE

In a disassembled carburetor, the position of the jet needle (pos. 3) can be changed. The standard position of the jet needle is 'position 2'. If the clip (pos. 4) is set in 'position 1' of the jet needle, the full mixture in part and full-load will become slightly leaner. If the clip (pos. 4) is set into 'position 5', the fuel mixture will become slightly richer in the part and full-load range.

NOTE

The fuel filter (pos. 32) is located below the fuel inlet on the carburetor, preventing contamination from entering the carburetor, which could impair operation of the carburetor.

Step	Procedure
6	Remove the hex. screw (pos. 34) and gasket ring (pos. 33).
7	Pull out the fuel filter (pos. 32) and clean the filter and fuel inlet.
8	Refit the fuel filter (pos. 32), the gasket ring (pos. 33) and hex. screw (pos. 34).

NOTE

When trying to start the engine it, will take a few seconds for the fuel pump to fill the float chamber and for the engine to start.

NOTE

With the adjustment screw (pos. 36), the idle speed of the engine can be adjusted. By turning in the adjustment screw (pos. 36) the idle speed increases and by turning out the screw (pos. 36) the idle speed will be reduced.

NOTE

With the adjustment screw (pos. 31), the fuel mixture formation can be adjusted. By turning in the adjustment screw (pos. 31), the air-fuel mixture will become richer at idling and by turning out the screw (pos. 31), the air-fuel mixture will become leaner at idling. The default setting of the adjustment screw are two full turns and one quarter of a turn (2 ¼) from inside to outside.

SELECTION OF THE TRANSMISSION RATIO

The transmission ratio (between chain pinion on the engine and chain sprocket on the rear axle of the kart) has an essential influence on the achievable lap time. The routing (fluent or non-fluent) and the conditions (high or low tire grip) of the track require a certain transmission ratio to ensure an optimal lap time.

A longer transmission ratio (e.g. $12/72=6$) theoretically results at every rotational speed of the engine in a higher speed of the vehicle, but also in a higher driving resistance than with a shorter transmission ratio (e.g. $12/78=6.5$).

Calculation Example:

Rotational speed 13000 rpm.

Transmission ratio $12/72=6$

Circumference of rear tire 0.85 m

Vehicle speed = $13000 \times 60 : 6 \times 0.85 : 1000 = 110.5 \text{ km/h}$

Rotational speed 13000 rpm.

Transmission ratio $12/82=6.5$

Circumference of rear tire 0.85 m

Vehicle speed = $13000 \times 60 : 6.5 \times 0.85 : 1000 = 102 \text{ km/h}$

In principle, the transmission ratio should be chosen in a way that the engine is mainly operated in a speed range at which the engine performance is well above the driving resistance.

The following chart (125 MAX evo) shows that the difference between the engine performance and the driving resistance constantly increases at a speed range from 5000 to 9000 rpm, remains the same at a speed range from 9000 to 11500 rpm and decreases again at a speed about 11500 rpm onwards.

The smaller the difference between the engine performance and the driving resistance gets, the smaller is the excess of power and thus the acceleration potential of the engine. The intersection between the characteristic of driving resistance of the vehicle and the characteristic of engine performance indicates the peak rotational speed of the engine at the chosen transmission ratio.

With the „longer“ transmission ratio of $12/72=6$, the characteristic of driving resistance of the kart intersects the curve of engine performance at 13000 rpm – with this transmission ratio the engine will achieve a maximum rotational speed of 13000 rpm. This leads to a maximum speed of 110.5 km/h.

With the „shorter“ transmission ratio of $12/78=6.5$ the characteristic of driving resistance of the kart stays below the curve of engine performance over the whole speed range - with this transmission ratio the engine will achieve a maximum rotational speed of 14000 rpm. This leads to a maximum speed of 109.8 km/h.

NOTE

If a transmission ratio is chosen that results in a maximum rotational speed of 14000 rpm, it does not automatically mean that this leads to the best lap time. With a fluent routing, even a “longer” transmission ratio with a lower maximum rotational speed can lead to a better lap time

BRP-Rotax Operators Manual

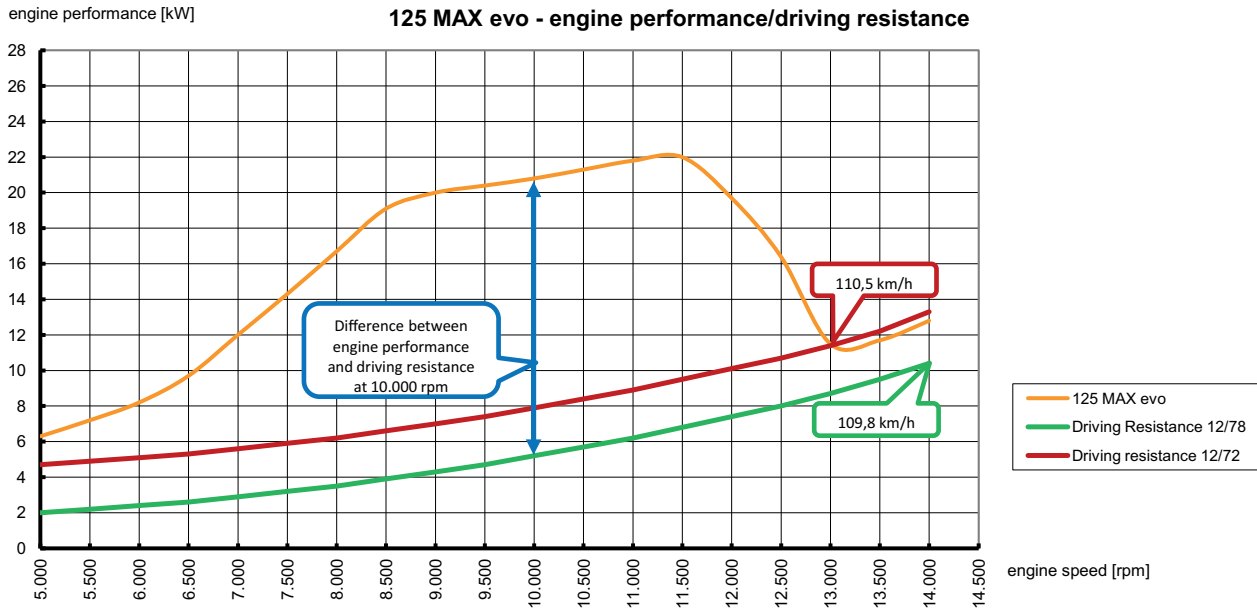

Figure 3.12

BRP-Rotax Operators Manual

EXCHANGE OF THE CLUTCH DRUM WITH CHAIN SPROCKET FITTED

Step	Procedure
1	Remove spark plug connector for safety.
2	Use the fixation tool (pos. 15) to lock the starter gear.
3	Remove hex. nut (pos. 14) and thrust washer (pos. 13). See Fig. Components of clutch.
4	Remove clutch drum (pos. 7) with fitted chain sprocket.
5	Clear thread of crankshaft and hex. nut (pos. 14) from remains of bonding agent and degrease.

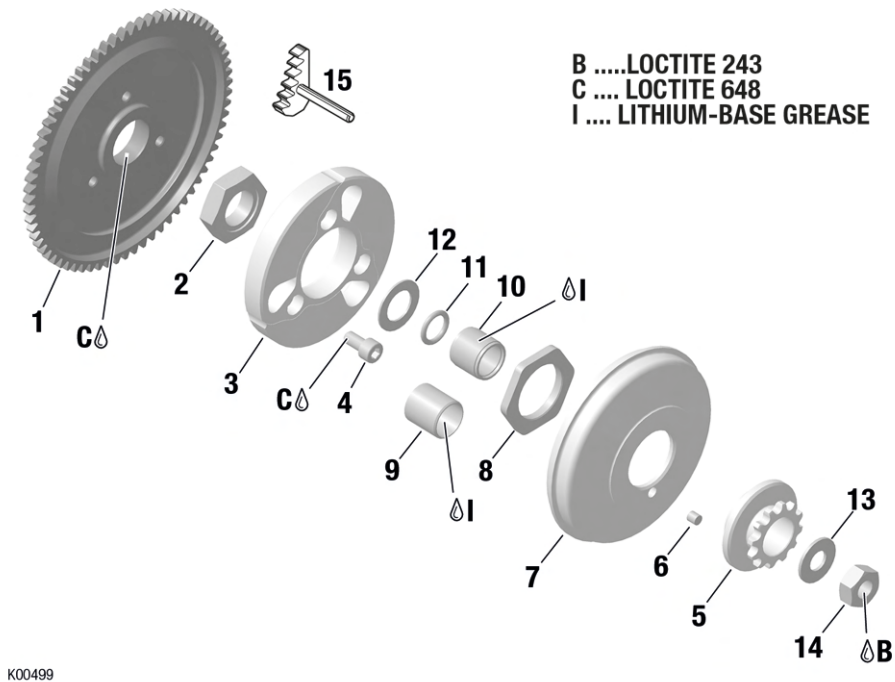

Figure 3.13: Components of clutch

1 Starter gear	2 Hex. nut M20x1.5	3 Clutch
4 Allen screw M6x12	5 Sprocket	6 Needle pin 5x5
7 Clutch drum	8 Hex. nut M28x1	9 Plain bearing 15x17x17.6
10 Needle cage K 15x19x7	11 O-ring 12x2.5	12 Thrust washer 15.2/25/1
13 Thrust washer 10/19/ 1.5	14 Hex. nut M10x1	15 Fixation tool assy.

BRP-Rotax

Operators Manual

NOTE

Only sprockets with the ROTAX® logo are GENUINE ROTAX® parts!

NOTE

For the chain sprocket with 11 teeth, use the plain bearing (pos. 9) instead of the needle cage (pos. 10). The plain bearing has to be pressed flush into the bore of the chain sprocket with chamfered end leading.

If not absolutely necessary on a certain track, try not to use a chain sprocket with 11 teeth because of the heavy wear of the plain bearing (pos. 10) used only with this sprocket.

Step	Procedure
6	Apply grease on needle cage (pos. 9) when using a chain sprocket with 12, 13 and 14 teeth or on plain bearing (pos. 10) for chain sprocket with 11 teeth.
7	Fit the assembled clutch drum with the selected number of teeth.
8	Apply LOCTITE 243 on the thread of hex. nut (pos. 14).

NOTE

A smaller thrust washer (pos. 13) is required for the chain sprocket with 11 teeth, in comparison to the use of a chain sprocket with 12, 13 and 14 teeth.

Step	Procedure
9	Fit thrust washer (pos. 13) and hex. nut (pos. 14) and tighten nut to 35 Nm / 310 in.lb.
10	Remove fixation tool.

CHANGING OR RENEWAL OF THE CHAIN SPROCKET ON THE CLUTCH DRUM

The chain sprocket (pos. 2) is attached to the clutch drum (pos. 4) with a hex. nut (pos. 5) and torque is transmitted by a needle pin (pos. 3) (see Fig.). The proper changing or renewal of the chain sprocket is only feasible when using the appropriate fixture (pos. 1, part no. 277364). To change or renew the chain sprocket, proceed as follows:

NOTE

The fixture is furnished on one side with a centering pin for the chain sprocket with 11 teeth (17 mm diameter) and on the other side with a centering pin for the chain sprocket with 12, 13 and 14 teeth (19 mm diameter / 0.75 in).

NOTE

On the chain sprocket with 11 teeth, the plain bearing must be pressed out first (the plain bearing must be renewed after pressing out).

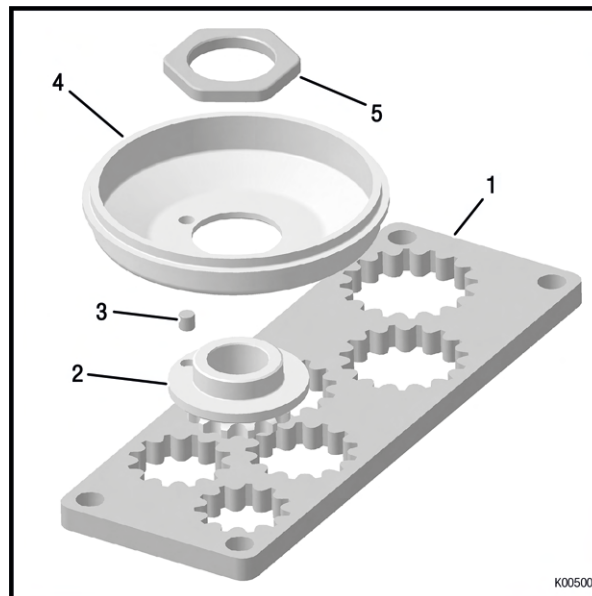

Figure 3.14: Fixation tool

- | | |
|------------------|---------------|
| 1 Fixation tool | 2 Sprocket |
| 3 Needle pin 5x5 | 4 Clutch drum |
| 5 Hex. nut | |

Step	Procedure
1	Clamp fixture (pos. 1) for the chain sprocket in a vice.
2	Place the clutch drum with chain sprocket on the respective centering pin so that the clutch drum is secured by the fixation pin.
3	Remove the hex. nut (pos. 5) from the chain sprocket.

BRP-Rotax Operators Manual

Step	Procedure
4	Clean all remains of the securing agent from the components.
5	Degrease the chain sprocket, the clutch hub and the hex. nut.
6	Place the new chain sprocket or the chain sprocket with required number of teeth on the respective centering pin of the fixture.
7	Place the needle pin (pos. 3) into the relevant bore of the chain sprocket.

NOTE

Fit the hex. nut (pos. 5) such that the machined face of the nut points towards the clutch drum.

Step	Procedure
8	Attach the chain sprocket with the hex. nut (pos. 5) to the clutch drum. Tightening torque 120 Nm / 89 lb ft.

BRP-Rotax
Operators Manual

Chapter: 4
ENGINE OPERATION

TOPICS IN THIS CHAPTER

ENGINE OPERATING	2
Engine start	2
Stopping the engine.....	4
Setting of the exhaust valve timing (125 MAX evo only).....	5
Maintenance schedule for engine components	8
Operating Limits.....	10

ENGINE OPERATING

ENGINE START

Before starting the engine, make sure you have completed all necessary tasks for running the engine:

- ✓ Fuel tank full.
- ✓ Battery charged and connected.
- ✓ Battery voltage over 12 V.
- ✓ Carburetor Bowden cable is moving freely and carburetor piston connected in idle position.

At engine start proceed as follows:

Step	Procedure
1	On a cold engine, pull the choke lever (pos. 1,) into a vertical position.

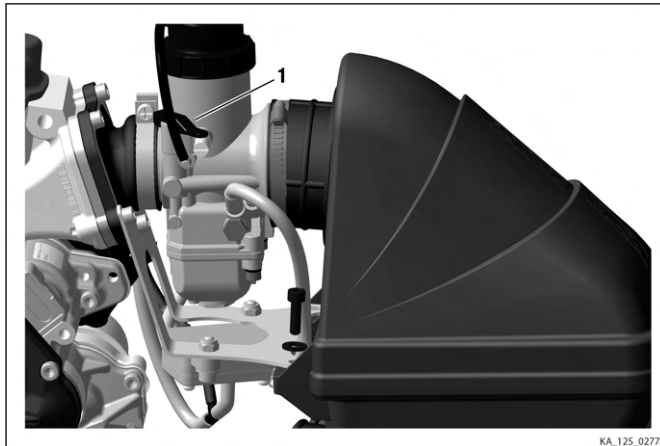

Figure 4.1: Choke lever

Step	Procedure
2	Press the power button once, the ignition system is activated (light turns on). Press the button again until the engine starts. See Fig. "Power button" NOTE <i>If the engine does not start, repeat the operation after a few seconds in the same manner.</i>

BRP-Rotax Operators Manual

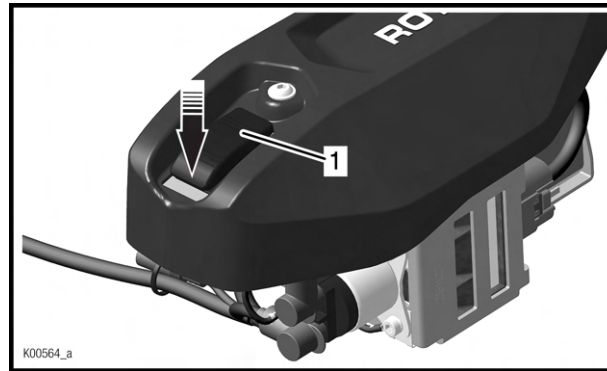

Figure 4.2: Power button

Step	Procedure
3	After engine start, take choke back until engine idles smoothly without choke.

⚠ WARNING

Non-compliance can result in serious injuries or death!

Always wear protective clothing for kart operation (helmet, overall, gloves, shoes, neck and rib guards).

⚠ CAUTION

Non-compliance can result in serious injuries!

Do not touch the engine, the radiator or the exhaust system during and immediately after kart operation. Risk of burning!

⚠ WARNING

Non-compliance can result in serious injuries or death!

During kart operation, beware of any contact of body or clothing with moving parts of the kart (drive chain, rear axle and wheels)..

⚠ WARNING

Non-compliance can result in serious injuries or death!

Comply with the safety advice of the engine and kart manufacturer.

⚠ WARNING

Non-compliance can result in serious injuries or death!

Inspect any part prone to wear (tyres, bearings etc.) before each kart event for good condition, in accordance with the directives of the kart manufacturer.

BRP-Rotax Operators Manual

NOTICE

Non-compliance can result in engine damage!
Keep to running-in procedure as directed.

NOTICE

Non-compliance can result in serious injuries or death!
Operate engine only within the specified limits and intended purpose.

⚠ WARNING

Non-compliance can result in serious injuries or death!
Only get in and out of the kart if engine is not running.

STOPPING THE ENGINE

See Fig. [Power button](#)

Step	Procedure
1	Press the power button and the engine will stop.

NOTE

If electric starter is activated, the ignition system will consume current. This can cause a deep discharge and damage to the battery.

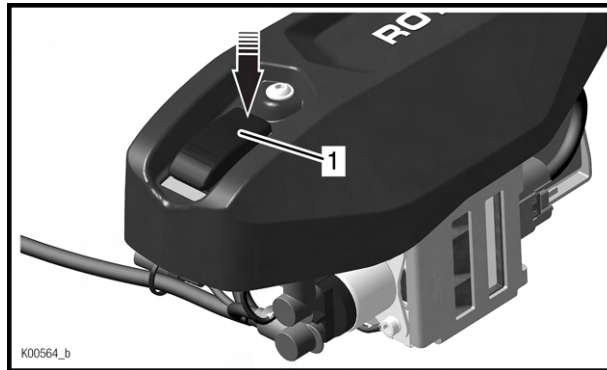

Figure 4.3: Power button

1 Power button

SETTING OF THE EXHAUST VALVE TIMING (125 MAX EVO ONLY)

Tools required:

- Allen key 4 mm or Socket wrench 8 mm

Due to the principle of equal parts, the harness for all MAX engines is identical. For engines without E-RAVE, the auxiliary cable (pos. 2, Fig.) must be attached and isolated to the ground cable so, that a possible contact with the engine ground does not affect the general function.

The opening time of the exhaust valve is set in the ECU and depends on the engine speed. However, the ECU allows two different modes of the exhaust valve opening. These can be selected by connecting an additional cable to the cylinder head cover.

NOTICE

The ground wire must be continuously connected.
This is important for the general function of the engine.

Variant 1: Additional cable on battery ground

A:

See [Ground wire](#)

The additional cable is **NOT** attached to the ground wire. The control of the exhaust valve timing is activated at 7900 rpm.

NOTE

Isolate the additional cable with an electrical/insulating tape to the ground wire so that a possible contact with the engine ground does not affect the function.

B:

See [Ground wire](#)

The additional cable is attached to the ground wire. The control of the exhaust valve timing is activated at 7600 rpm.

BRP-Rotax Operators Manual

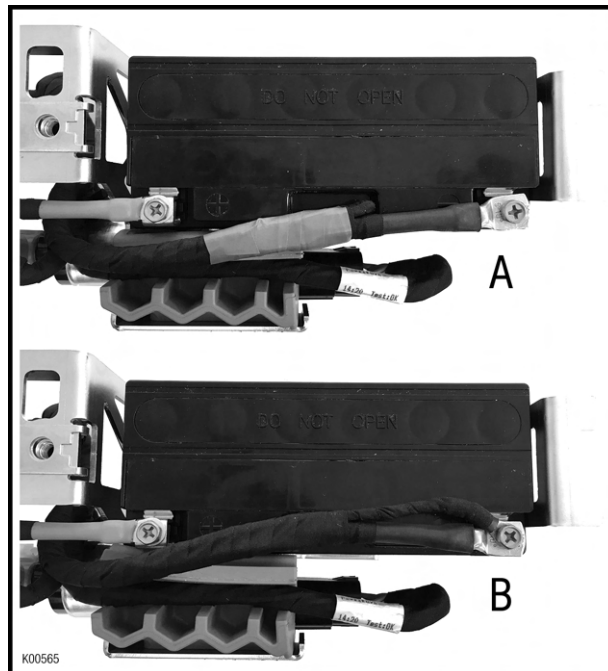

Figure 4.4: Ground wire

Variant 2: Additional cable on starter relay

A:

See [Cable on starter relay](#).

The additional cable is **NOT** attached to the ground wire. The control of the exhaust valve timing is activated at 7900 rpm.

NOTE

Isolate the additional cable with an electrical/insulating tape to the ground wire so that a possible contact with the engine ground does not affect the function.

B:

See [Cable on starter relay](#).

The additional cable is attached to the ground wire. The control of the exhaust valve timing is activated at 7600 rpm.

BRP-Rotax
Operators Manual

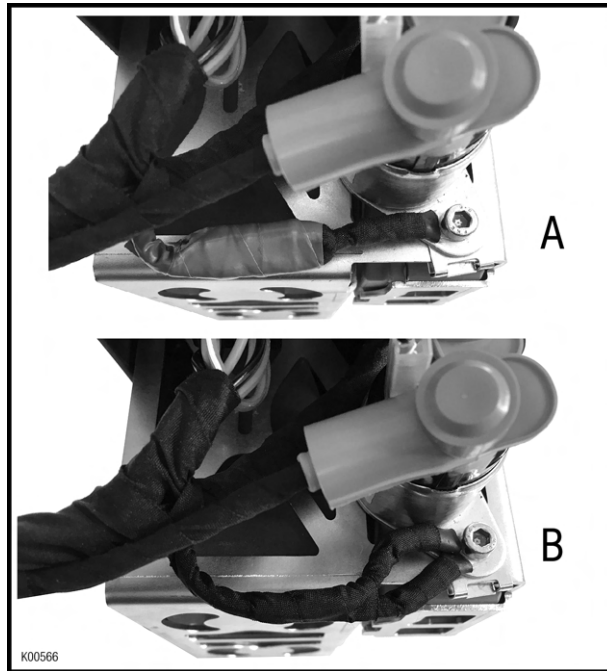

Figure 4.5: Cable on starter relay

NOTE

Either variant 1 or variant 2 has been installed in your engine.

BRP-Rotax
Operators Manual

MAINTENANCE SCHEDULE FOR ENGINE COMPONENTS

NOTICE

Non-compliance with the specified maintenance schedule could result in engine damage.

ENGINE	FREQUENCY						NOTES
	Before every operation	After every operation	Every 2 hours of operation	Every 5 hours of operation	Every 10 hours of operation	Every 50 hours of operation	
Chain sprocket	X						Inspection for wear and deformation of teeth. Renew as required.
Exhaust system		X					Lubricate against corrosion.
Clean airfilter, apply oil, replace in case of visible damage.				X			After each rainy session, use air filter cleaner kit.
Fuel filter			X				Inspect for dirt.
						X¹⁾	Renew, ¹⁾ at least once a year.
Water pump	X						Inspect for oil or water on the leakage bore in the crankcase. In case of leakage, have a teardown inspection conducted by the authorized distributor.
Cooling circuit connections	X						Verify a tight fit and non leakage. Re-tighten or renew as required.
Oil level in the gear compartment			X				Check oil level, replenish as required.

BRP-Rotax
Operators Manual

ENGINE	FREQUENCY						NOTES
	Before every operation	After every operation	Every 2 hours of operation	Every 5 hours of operation	Every 10 hours of operation	Every 50 hours of operation	
Drive gears for balance shaft					X		Inspect for wear, renew as required.
Oil in the gear compartment						X¹⁾	Renew, ¹⁾ at least once a year.
Starter gear					X		Cleaning and greasing of bearing seals.
Needle bearing or plain bearing of the clutch drum			X				Cleaning and greasing, renew as required.
Friction lining of the fly weights					X		Inspect for wear, renew as required.
Damping material in the after muffler of the exhaust system					X		Renew.
Tear-down inspection of engine (must be conducted by an authorized ROTAX Service Center)						X	Inspect following components and replace if requested: Piston, piston pin and piston bearing cage, conrod and conrod bearing, main bearings of crankshaft, drive of balance shaft, sealing of water pump shaft.
RAVE			X				Clean hoses with compressed air.

BRP-Rotax

Operators Manual

OPERATING LIMITS

Operating the engine is only permitted under following conditions:
Recommended coolant temperature rang: 45 °C – 85 °C (113 °F – 185 °F).

NOTICE

Operating the engine at a too low temperature could result in piston seizure.
The engine is only allowed to be run at peak performance after reaching the specified operating temperature.

NOTE

If the engine does not reach the minimum specified operating temperature due to the low ambient temperature, then the cooling efficiency of the radiator must be reduced by partially covering the radiator with adhesive tape.

NOTICE

Non-compliance can result in engine damage!
The maximum operating temperature of the engine must not be exceeded. If the temperature is too high, it may result in piston seizure.

NOTE

Dirt must be cleared from the lamination of the radiator at regular intervals to achieve the best cooling performance.

Chapter: 5
PRESERVATION AND TRANSPORT

TOPICS IN THIS CHAPTER

Preservation and transport	2
Preservation of engine and equipment	2
Transport of the kart.....	2
IMPORTANT INFORMATION (SUMMARY).....	3
Notes	4

PRESERVATION AND TRANSPORT

PRESERVATION OF ENGINE AND EQUIPMENT

For longer periods out of operation (winter time), make sure that the engine will be properly preserved.

Step	Procedure
1	Detach carburetor, drain fuel from carburetor and close carburetor openings to ensure that no dust or dirt can enter.
2	If the vehicle gets stored at temperatures below freezing, drain the entire cooling system and clean the cooling circuit with pressure air.

NOTICE

Not following this may lead to engine damage.

Step	Procedure
3	Close intake and exhaust port of engine with adhesive tape so that they are airtight.
4	Apply oil on exhaust system to prevent corrosion.
5	Remove battery from the fixture and charge periodically with the specified battery charger.

TRANSPORT OF THE KART

If the carburetor is still filled with fuel, the kart is only allowed to be transported in a horizontal position.

If the kart is to be transported in a vertical position, the fuel must be drained from the carburetor first.

NOTE

If the kart is in a vertical position at transport, the remaining fuel in the carburetor might flow into the crankcase with the result that the engine won't start at next try.

Step	Procedure
1	Remove drain screw on float chamber of carburetor and collect the fuel in a suitable container.
2	Clean drain screw and refit.

BRP-Rotax
Operators Manual

IMPORTANT INFORMATION (SUMMARY)

IMPORTANT INFORMATION	Liter	GAL.	SPECIFICATION	RECOMMENDED BRANDS
FUEL			Unleaded fuel of minimum octane level of 95 ROZ resp. 91 MOZ	
2-STROKE OIL			Fully synthetic	XPS Kart-Tec
OIL IN FUEL MIXING RATIO			During break-in: 1:33 (=3% oil) During normal use: 1:50 (=2% oil)	
COOLING SYSTEM	0.80	0.21	Pure water (if kart is stored at temperatures below 0 °C/ 32 °F: drain the system)	
BALANCE DRIVE GEARBOX OIL	0.10 (100 cc)		Engine oil SAE 15W-40	XPS Kart-Tec
SPARK PLUG			see IPC	NGK

BRP-Rotax Operators Manual

Index

A

Automatic-set-up.....5

B

Balance shaft.....2

Battery and battery charging unit.....2

Battery charging unit.....4

C

Carburetor.....3

Carburetor calibration.....4

Centrifugal clutch.....4

Change of the carburetor main jet.....12

Changing or renewal of the chain sprocket on
the clutch drum.....19

Coolant.....2

Cooling circuit.....2

D

Design of the ROTAX engine, Type 125 MAX.....2

E

Electric starter.....2

Electro pneumatically exhaust timing control.....3

Engine calibration.....2

Engine operating.....2

Engine operation.....1

Engine start.....2

Exchange of the clutch drum with chain
sprocket fitted.....17

Exhaust system.....3

F

Fuel.....5

Fuel pump.....3

G

General.....2

I

Ignition unit.....2

IMPORTANT INFORMATION (SUMMARY).....3

Intake silencer.....3

INTRO.....1

M

Maintenance schedule for engine components.....8

Manual set-up.....8

N

NOTES.....4

O

Operating fluids and battery.....2

Operating limits.....10

P

Performance graphs.....2

Preservation and transport.....2

Preservation of engine and equipment.....2

R

Running-in procedure, Run-in procedure.....2

S

Selection of the transmission ratio.....15

Setting of the exhaust valve timing.....5

Stopping the engine.....4

T

Technical Description.....1

Transport of the kart.....2

ROTAX[®]

